

THE INFORMATION CONTAINED IN THIS DRAWING IS THE SOLE PROPERTY OF BUD INDUSTRIES INC. ANY REPRODUCTION IN PART OR WHOLE WITHOUT THE WRITTEN PERMISSION OF BUD INDUSTRIES INC. IS PROHIBITED.

DWG. NO.	AN-2901
ISSUE	REVISIONS

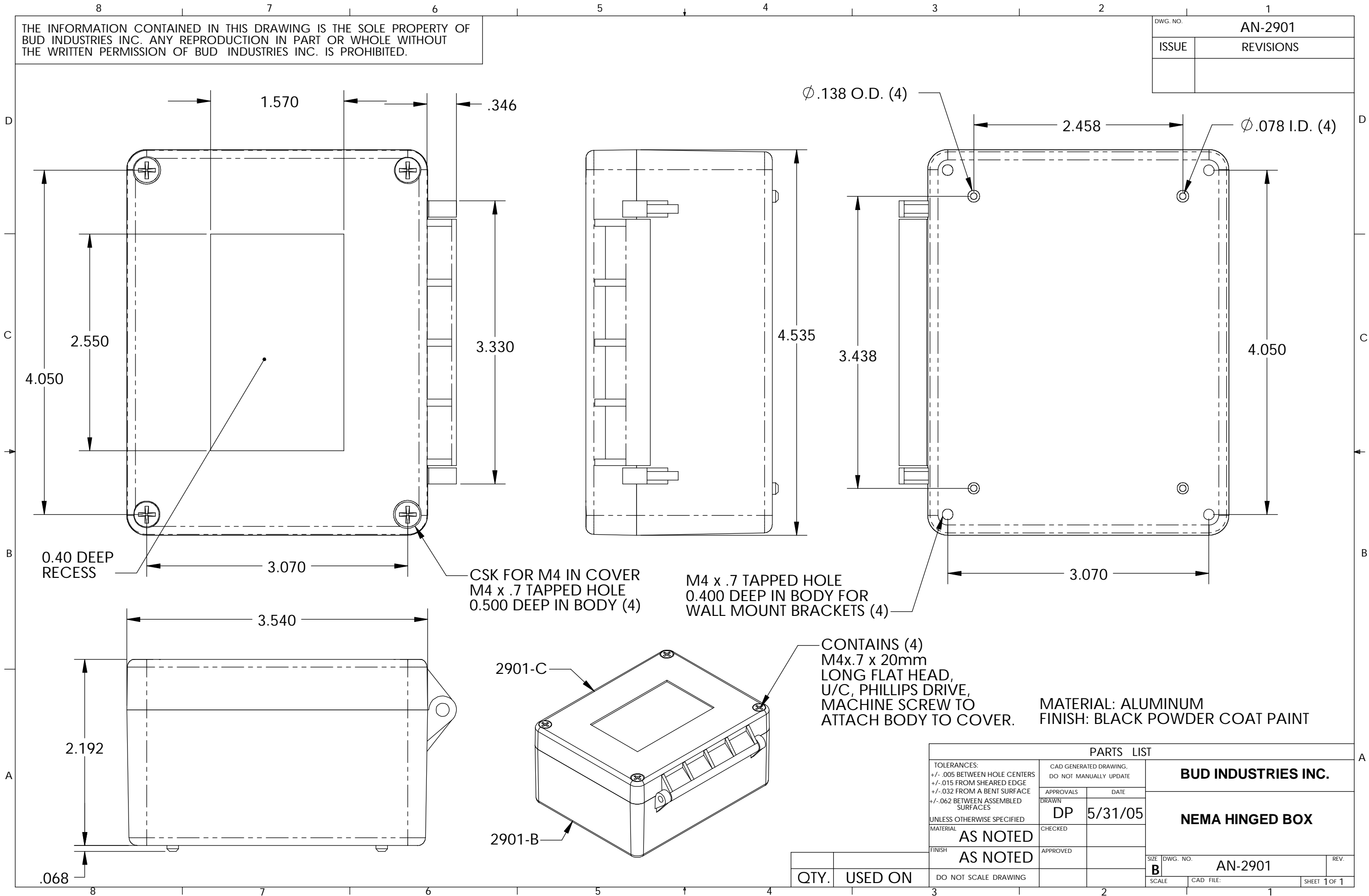

PARTS LIST			
TOLERANCES: +/- .005 BETWEEN HOLE CENTERS +/- .015 FROM SHEARED EDGE +/- .032 FROM A BENT SURFACE +/- .062 BETWEEN ASSEMBLED SURFACES UNLESS OTHERWISE SPECIFIED	CAD GENERATED DRAWING, DO NOT MANUALLY UPDATE	BUD INDUSTRIES INC.	
MATERIAL AS NOTED	APPROVALS DRAWN DP	DATE 5/31/05	NEMA HINGED BOX
FINISH AS NOTED	CHECKED	APPROVED	SIZE DWG. NO. B AN-2901
DO NOT SCALE DRAWING	SCALE	CAD FILE:	REV. SHEET 1 OF 1

QTY.	USED ON